



HITTITE

SOLAR ENERGY

Istanbul, Turkey

Contact : info@hittitesolar.com
Web Page : www.hittitesolar.com



HITTITE
At SolarTAC
Denver, Colorado

[DSG Video](#)

**HITTITE Developed Solutions and Achieved
Direct Steam Generation (DSG) in Parabolic Trough System**

**Heat Receivers rotate in all
existing designs,
preventing high pressure
Direct Steam Generation (DSG)**

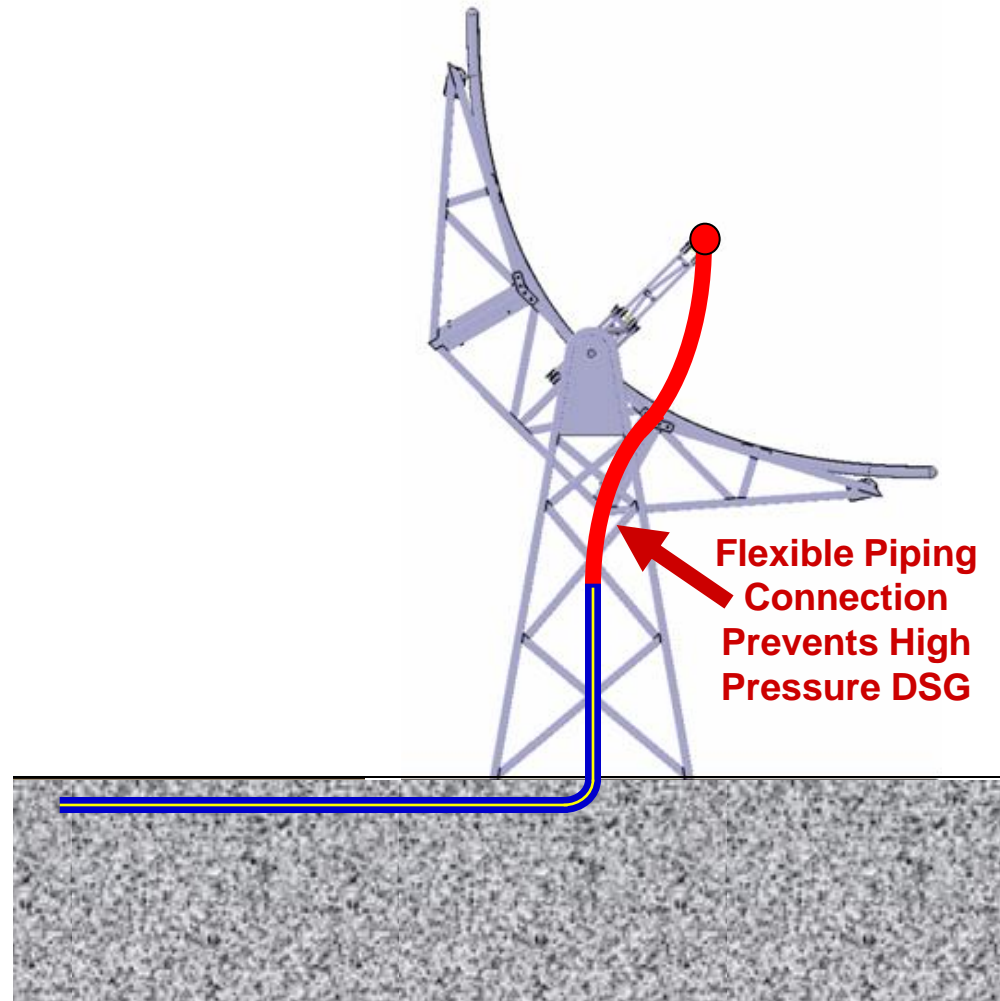



HITTITE Developed and Patented a Solution That **ALLOWS DIRECT STEAM GENERATION (3000 Psi & 1000 F)**

**HITTITE Heat Receiver is stationary.
All piping connections are welded
and flanged,
eliminating obstacles for DSG...**

**HITTITE is the only company in the
world to achieve DSG at
3000 Psi - 1000 F (250 Bar – 570C).**

**Heat Receivers rotate in all
existing designs,
preventing high pressure
Direct Steam Generation (DSG)**

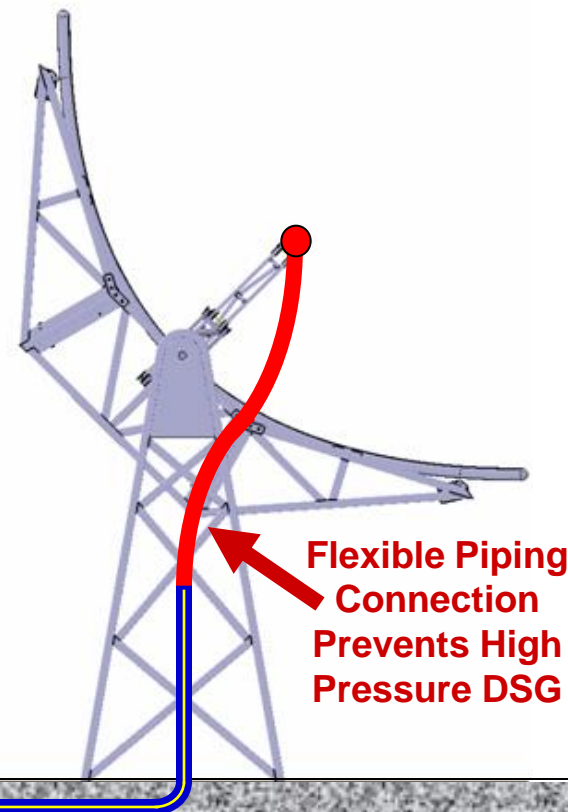
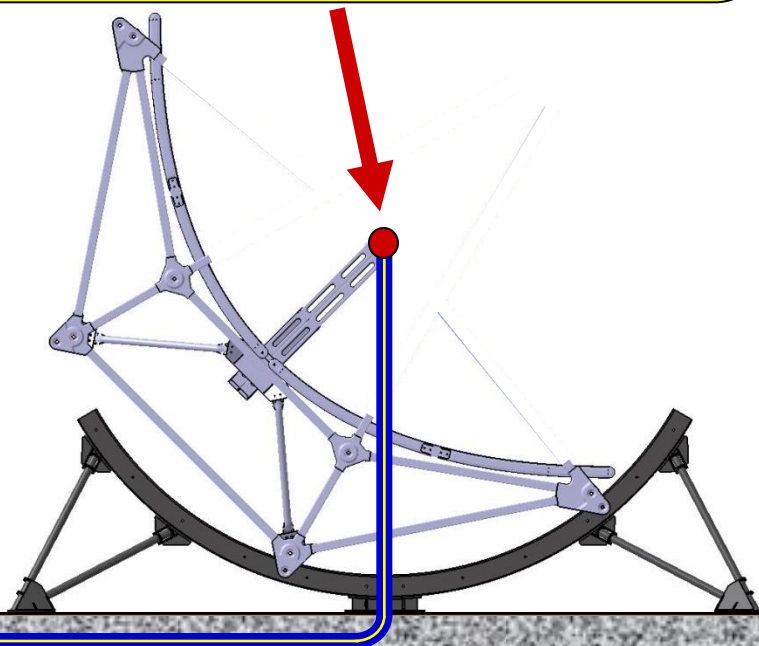



HITTITE Developed and Patented a Solution That **ALLOWS DIRECT STEAM GENERATION (3000 Psi & 1000 F)**

HITTITE Heat Receiver is stationary.
All piping connections are welded
and flanged,
eliminating obstacles for DSG...

HITTITE is the only company in the world to achieve DSG at 3000 Psi - 1000 F (250 Bar – 570C).

Heat Receivers rotate in all existing designs,
preventing high pressure
Direct Steam Generation (DSG)

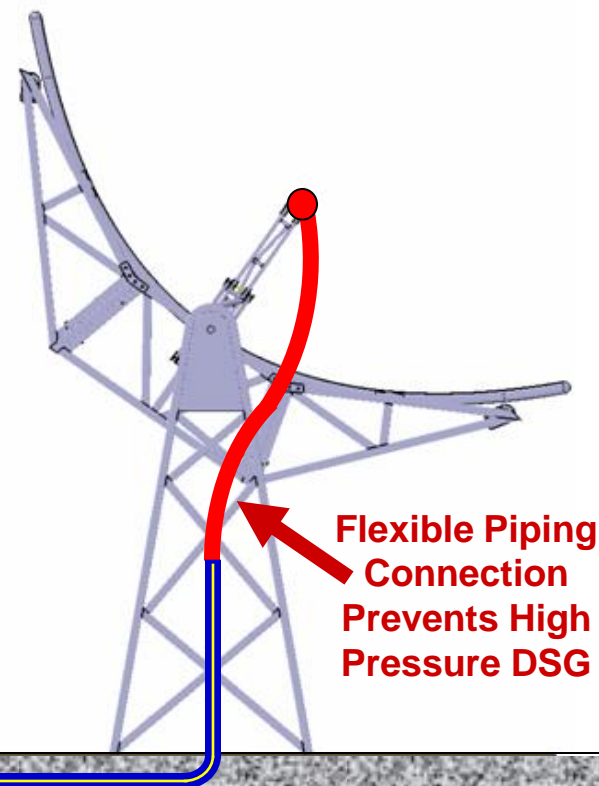
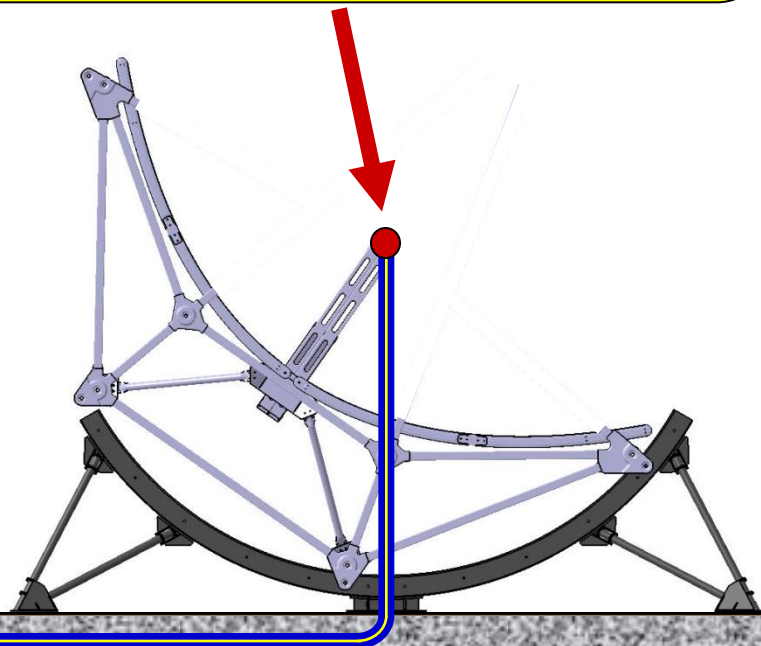



HITTITE Developed and Patented a Solution That **ALLOWS DIRECT STEAM GENERATION (3000 Psi & 1000 F)**

**HITTITE Heat Receiver is stationary.
All piping connections are welded
and flanged,
eliminating obstacles for DSG...**

**HITTITE is the only company in the
world to achieve DSG at
3000 Psi - 1000 F (250 Bar – 570C).**

**Heat Receivers rotate in all
existing designs,
preventing high pressure
Direct Steam Generation (DSG)**

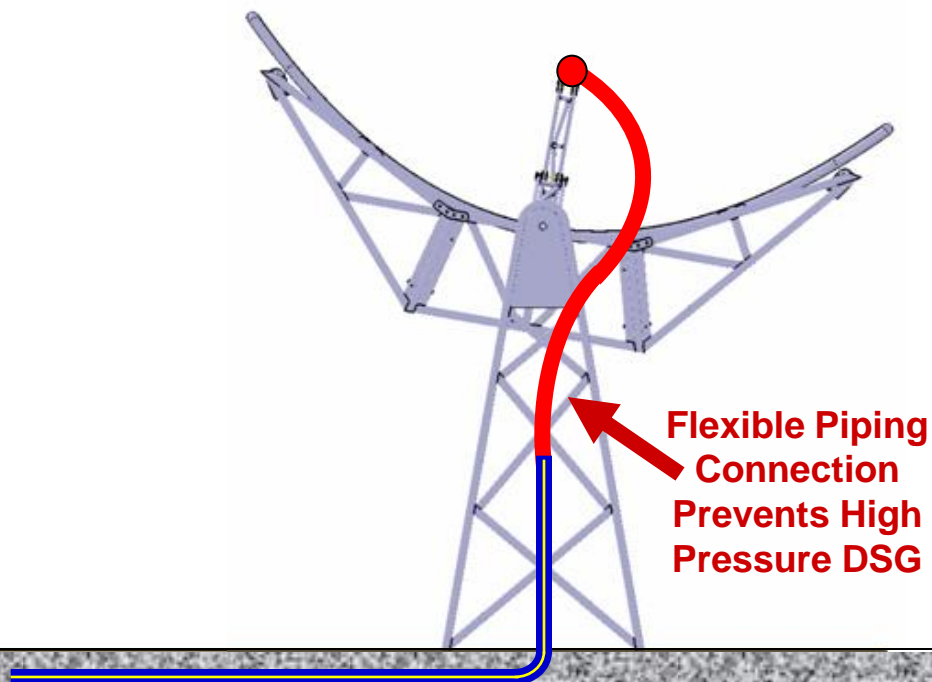
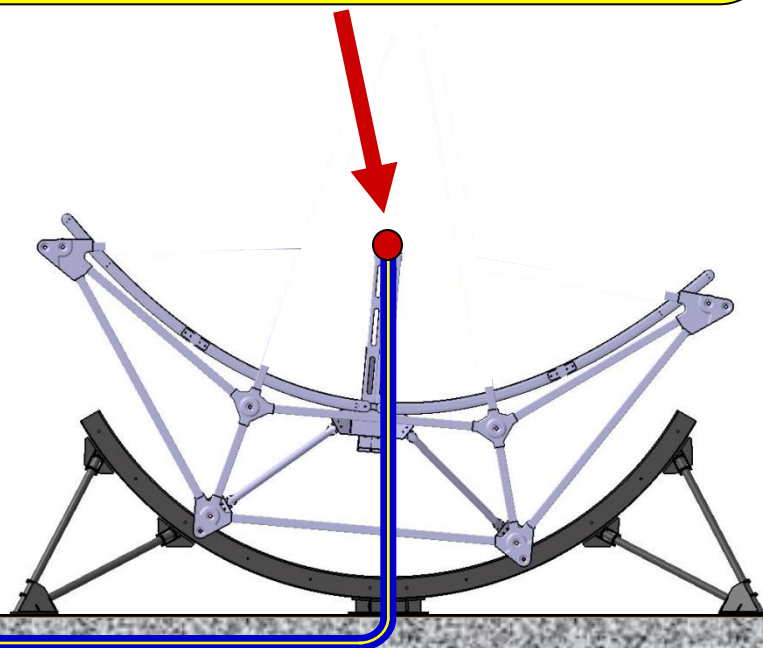



HITTITE Developed and Patented a Solution That **ALLOWS DIRECT STEAM GENERATION (3000 Psi & 1000 F)**

**HITTITE Heat Receiver is stationary.
All piping connections are welded
and flanged,
eliminating obstacles for DSG...**

**HITTITE is the only company in the
world to achieve DSG at
3000 Psi - 1000 F (250 Bar – 570C).**

**Heat Receivers rotate in all
existing designs,
preventing high pressure
Direct Steam Generation (DSG)**

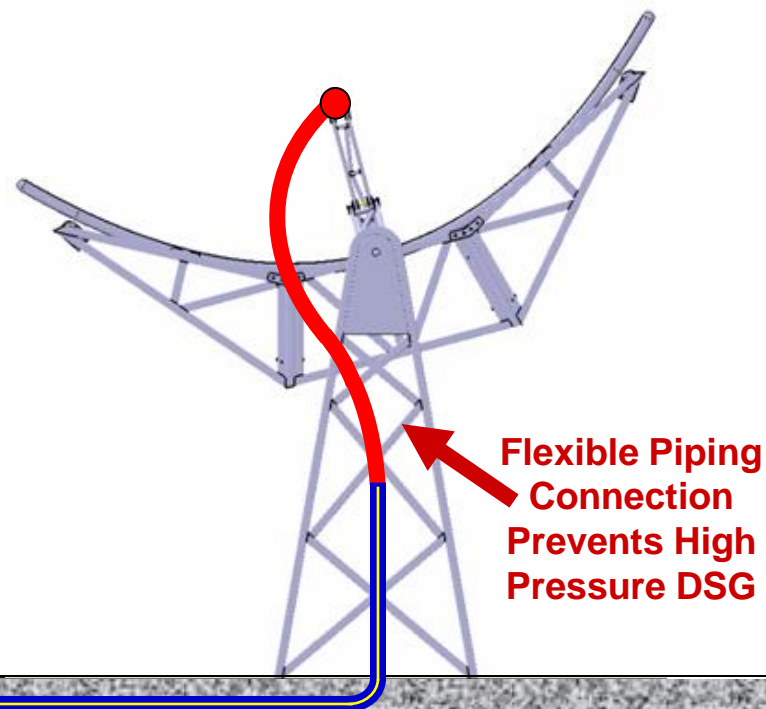
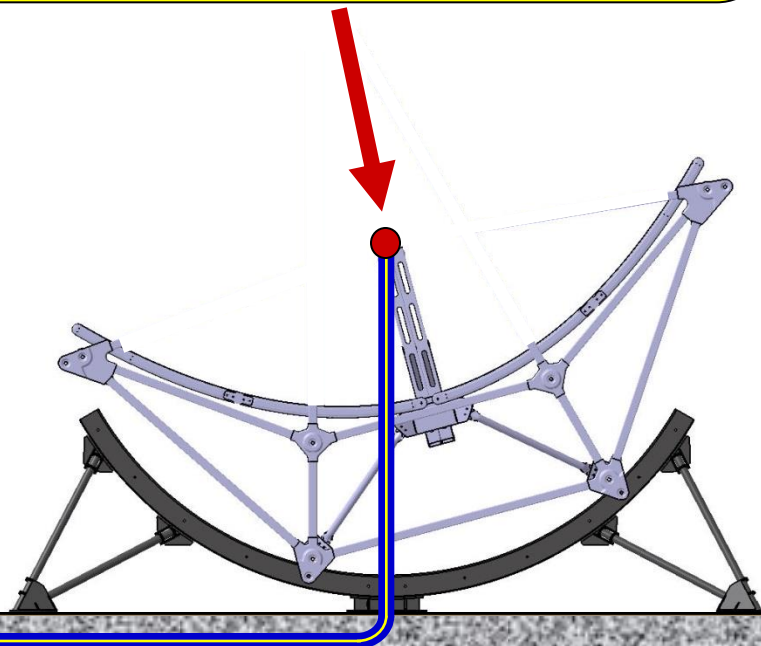



HITTITE Developed and Patented a Solution That **ALLOWS DIRECT STEAM GENERATION (3000 Psi & 1000 F)**

**HITTITE Heat Receiver is stationary.
All piping connections are welded
and flanged,
eliminating obstacles for DSG...**

**HITTITE is the only company in the
world to achieve DSG at
3000 Psi - 1000 F (250 Bar – 570C).**

**Heat Receivers rotate in all
existing designs,
preventing high pressure
Direct Steam Generation (DSG)**

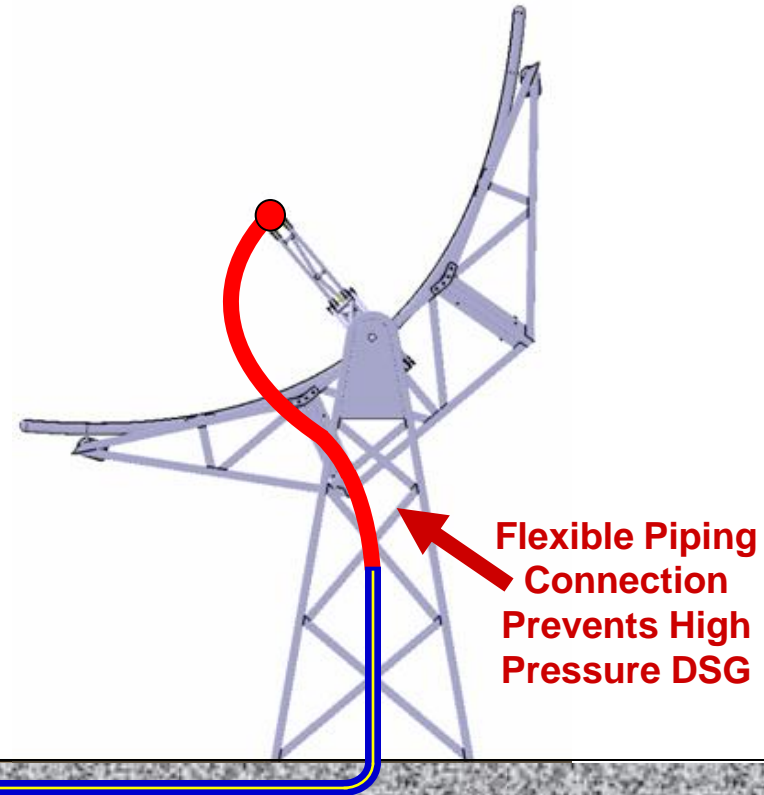
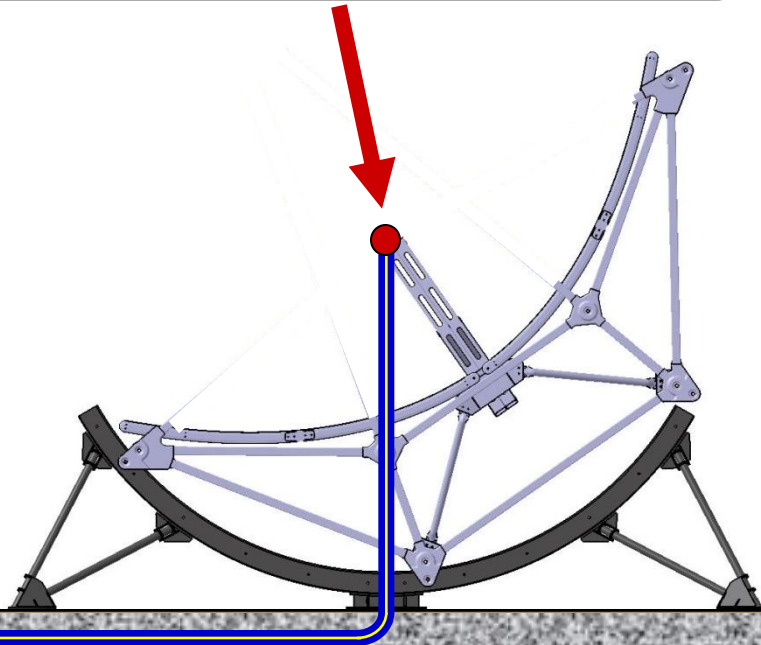



HITTITE Developed and Patented a Solution That **ALLOWS DIRECT STEAM GENERATION (3000 Psi & 1000 F)**

**HITTITE Heat Receiver is stationary.
All piping connections are welded
and flanged,
eliminating obstacles for DSG...**

**HITTITE is the only one in the world
to achieve DSG at
3000 Psi - 1000 F (250 Bar – 570C).**

**Heat Receivers rotate in all
existing designs,
preventing high pressure
Direct Steam Generation (DSG)**

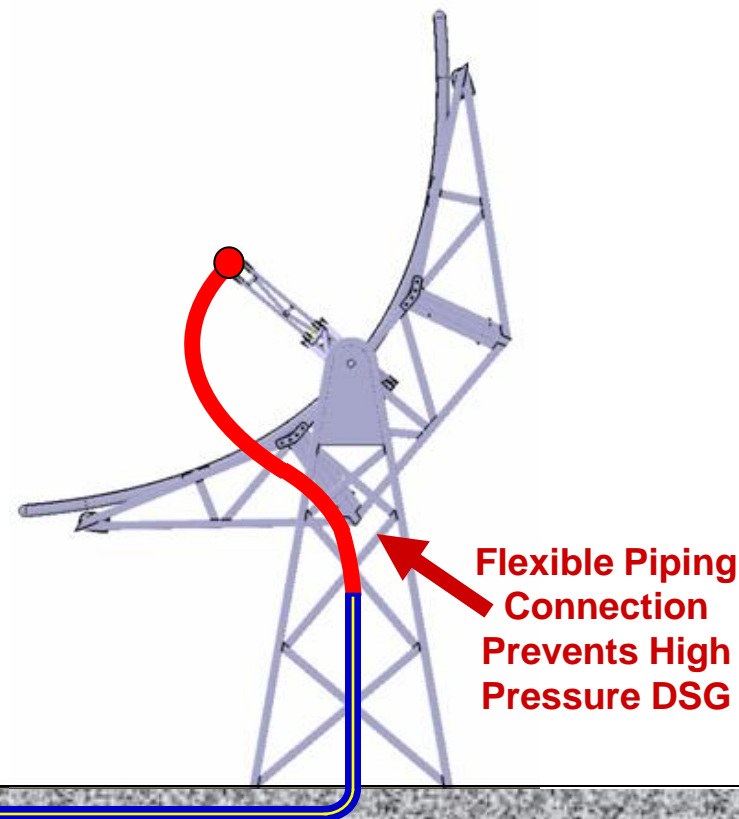
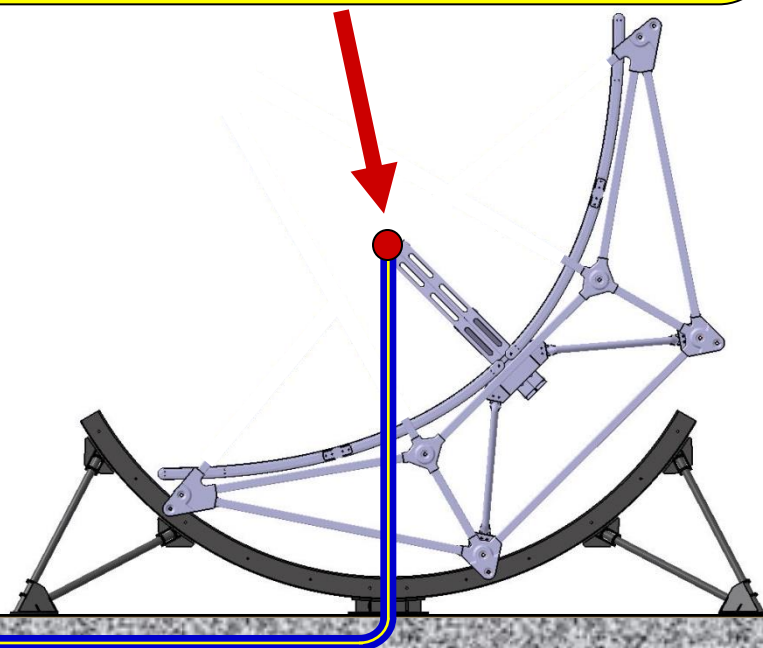

HITTITE Developed and Patented a Solution That **PREVENTS THE NEED FOR WIND BARRIERS**



HITTITE Parabolic Trough is locked in with wheels, eliminating the need for costly Wind Barriers.

Plot Type: Static node stress (Top) Stress
Deformation scale: 1

Storage Position Analysis For Storm Conditions

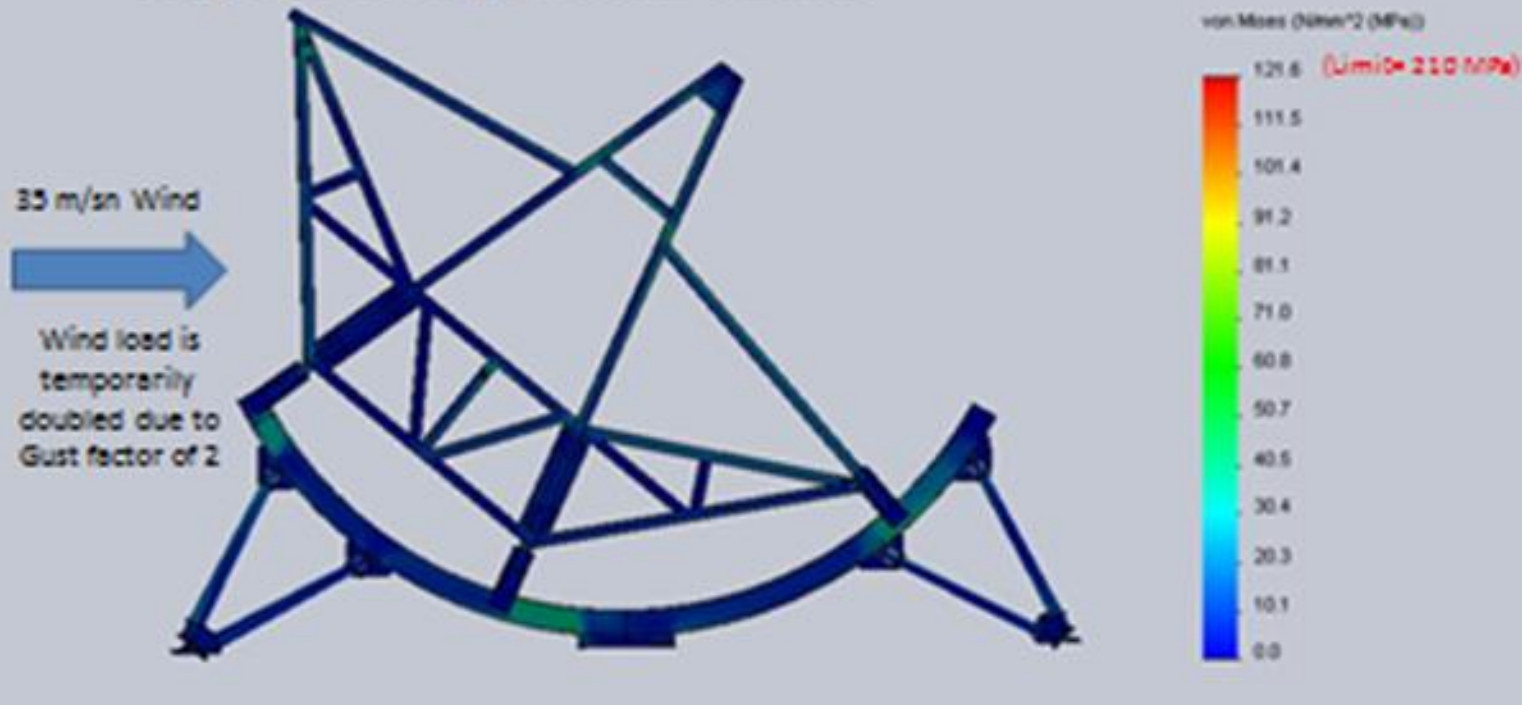

Storm Position Capacity (No wind barriers used):

126 Km/Hr. (78MPH) continuous wind

180 Km/Hr. (112MPH) short term gusts

If wind barrier is used, above wind speed limits may be increased by

50%.

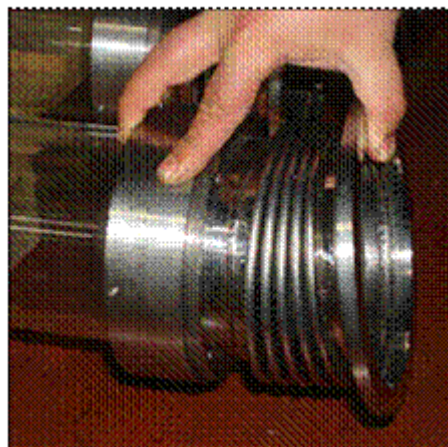
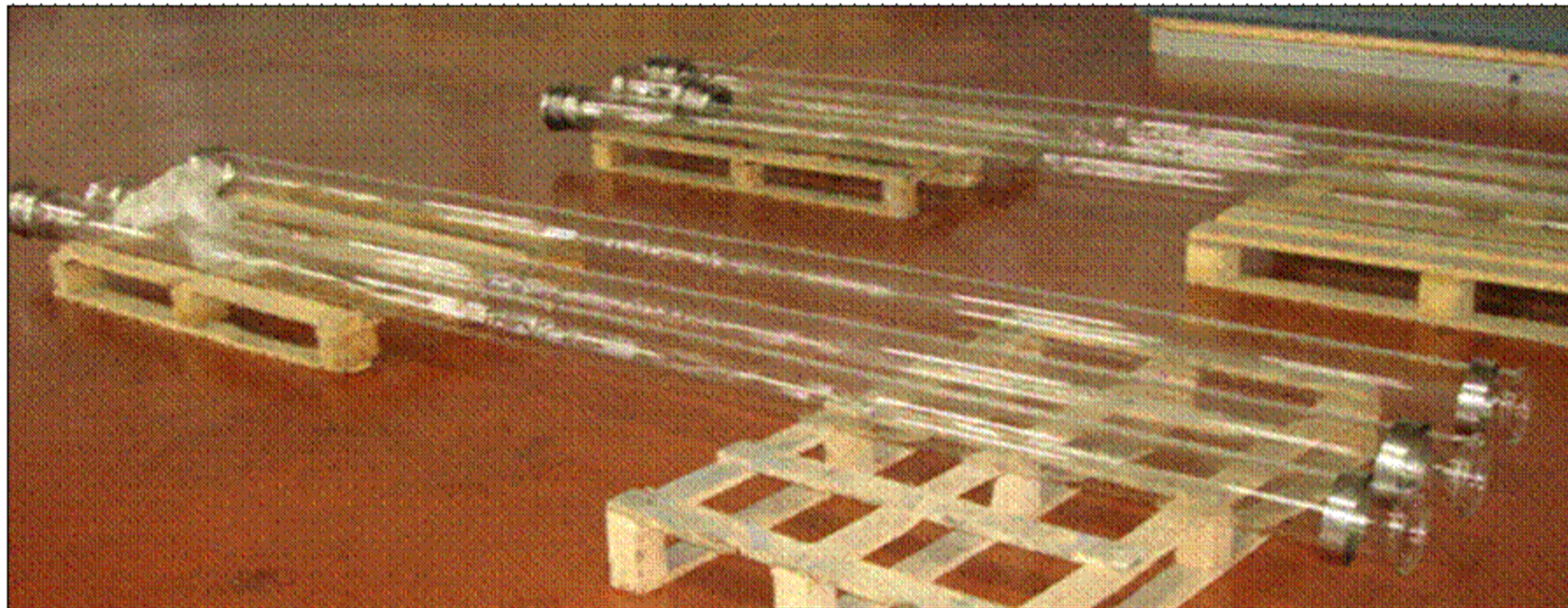

- ***HITTITE Heat Receiver allows for high degrees of vacuum to be maintained in field as required.***
- ***HITTITE Heat Receiver does not use “glass to metal welding”.***
- ***It can be assembled and maintained in the field, significantly reducing O&M costs.***

**Heat Receiver Support Designs Commonly Used
Cause Stresses and Have Limited Heat Expansion Capacity**

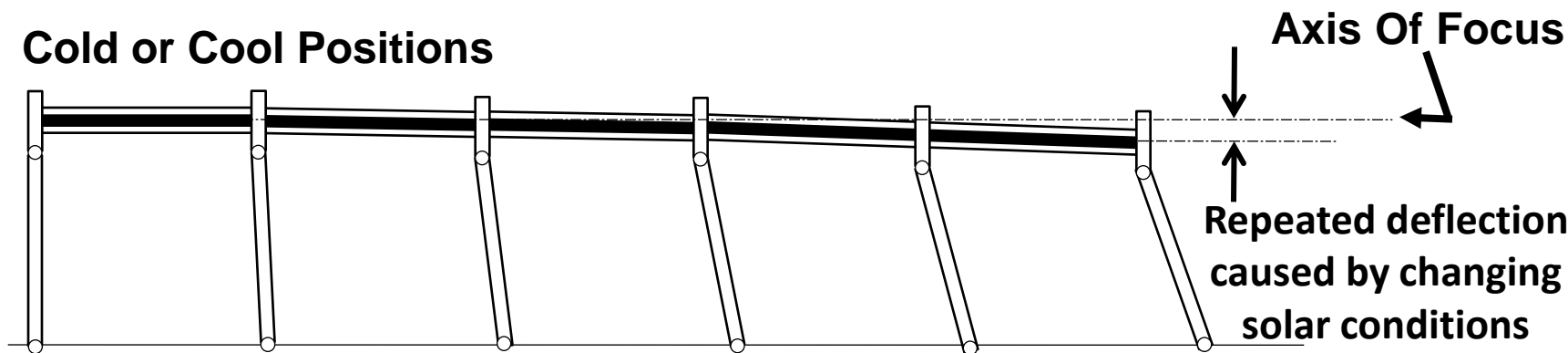
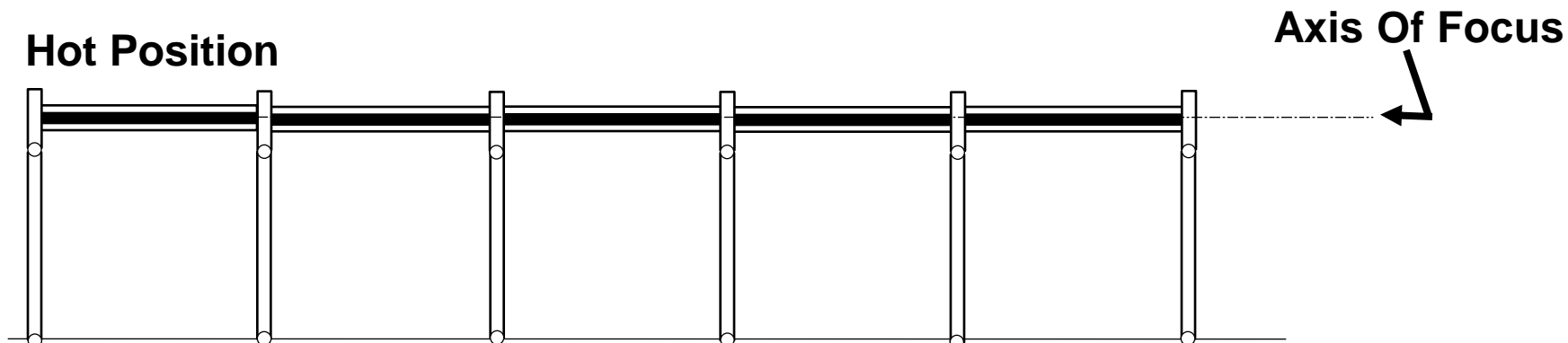

HITTITE Developed and Patented a Solution That **ALLOWS SIGNIFICANTLY MORE HEAT EXPANSION WITHOUT ANY DEFLECTION**

Axis Of HITTITE Heat Receiver is Stationary During Heat Expansion

Heat Expansion Capacity 55 Inch (140Cm)

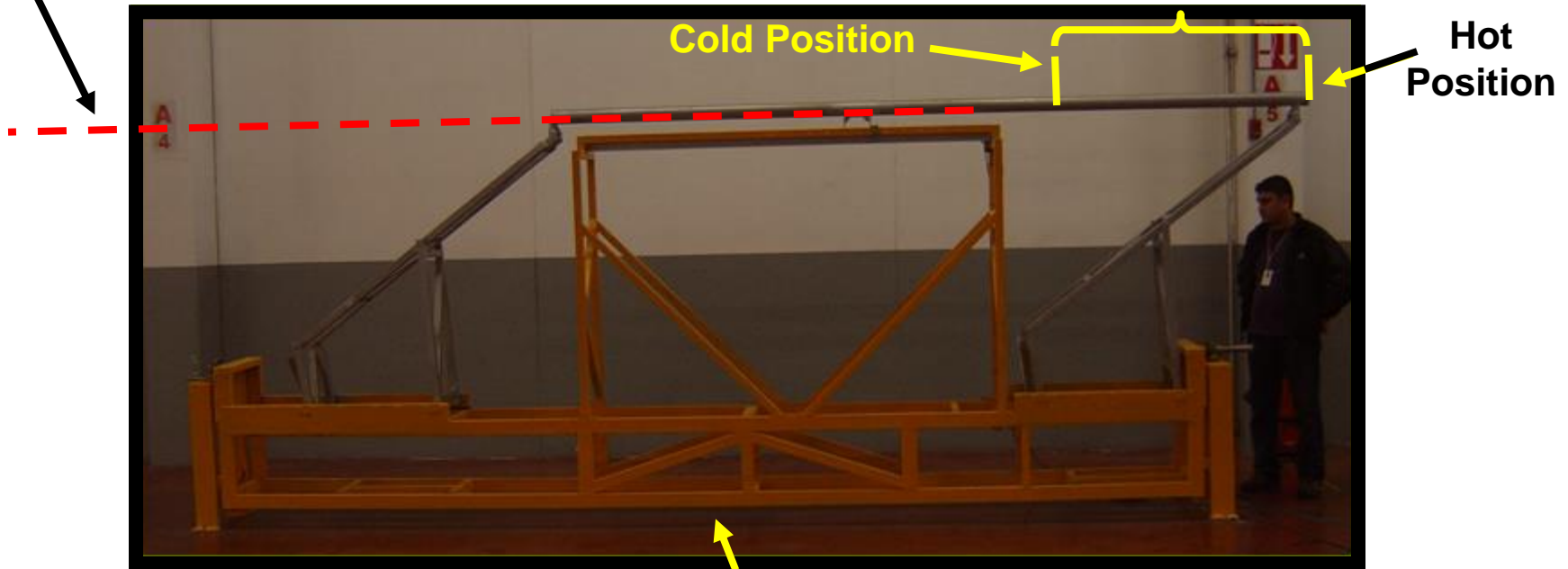

Cold Position

Hot Position

Yellow colored unit is the Laser Test Stand



HITTITE Developed and Patented a Solution That **PREVENTS MIRROR BREAKAGE** AND INCREASES MIRROR REFLECTIVITY

Strips of thin (1.5mm) flat mirror panels pasted on strong parabolic structure significantly reduce cost and increase mirror reflectivity

HITTITE Parabolic Mirrors are strong enough to carry the weight of several individuals



HITTITE consecutively built 5 Pilot Projects in Turkey to test and improve its design and conducted a “30 Year Accelerated Life Test”





HITTITE consecutively built 5 Pilot Projects in Turkey to test and improve its design and conducted a “30 Year Accelerated Life Test”



HITTITE consecutively built 5 Pilot Projects in Turkey to test and improve its design and conducted a “30 Year Accelerated Life Test”

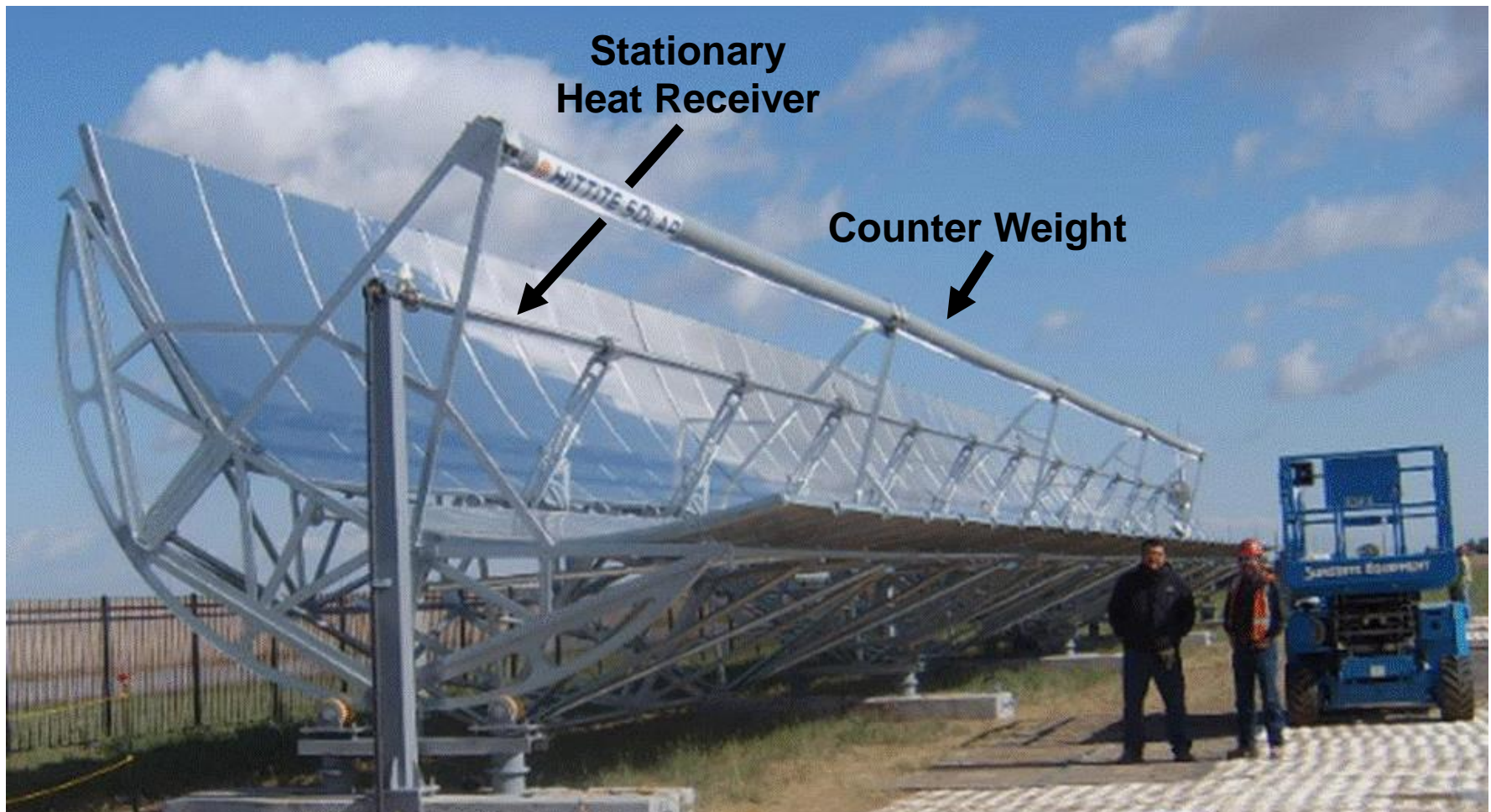

HITTITE Counterweight provides better stability and significantly accurate solar tracking.

HITTITE consecutively built 5 Pilot Projects in Turkey to test and improve its design and conducted a “30 Year Accelerated Life Test”

**“30 Year Equivalent Accelerated Life Test”
Of Direct Steam Generation at 410C (770F)**

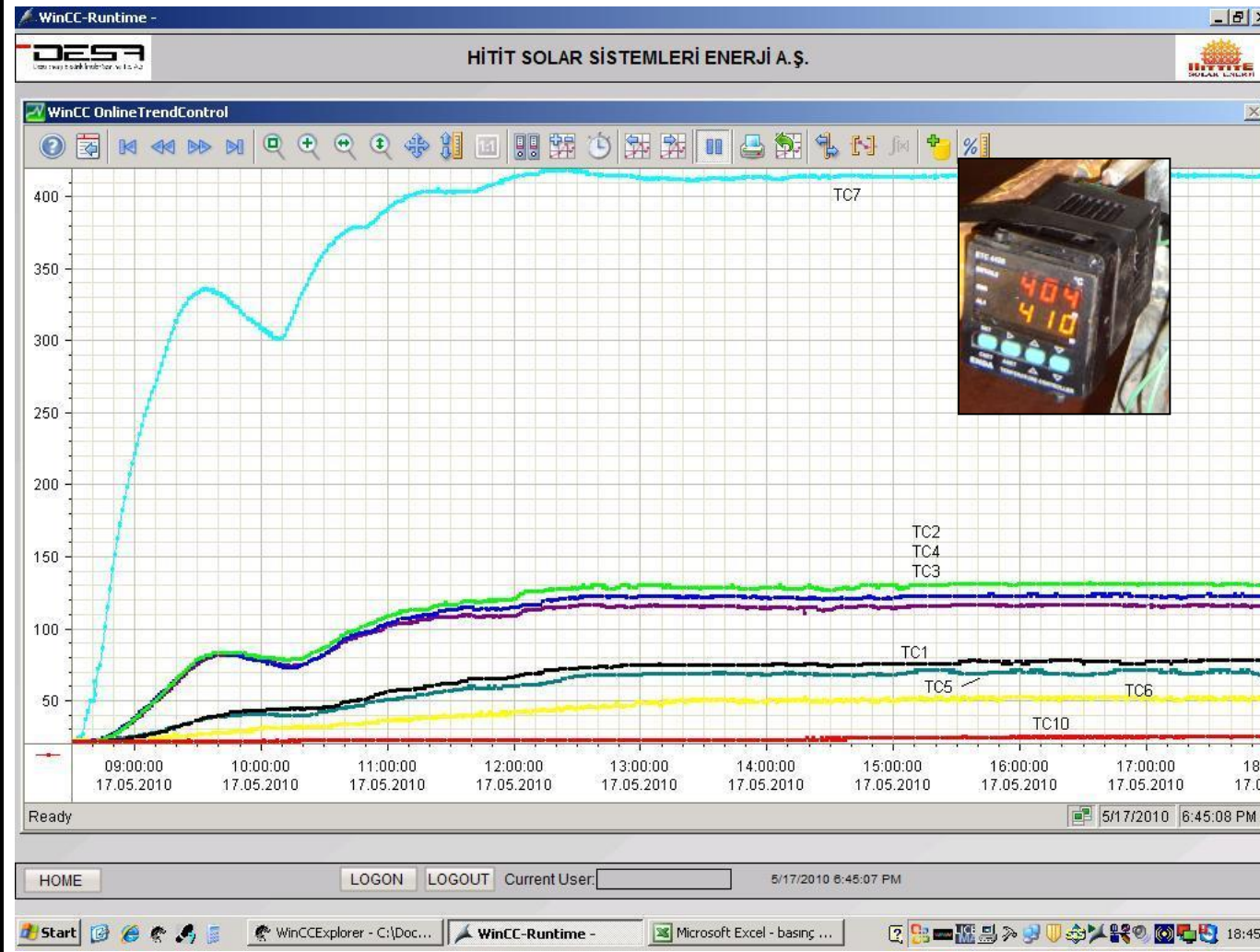

**HITTITE Desalinization Unit
Works with Low Temperature Waste Heat**



**HITTITE
DSG Solar Thermal Energy Pilot**



PAUL WOLFOVITZ
President, World Bank
(2005-2007)

R. OĞUZ ÇAPAN
Chairman & Chief Tec Officer
Hittite Solar Energy

*HITTITE DESALINIZATION TECHNOLOGY
won the "DM2006" COMPETITION
FROM AMONG 2550 APPLICANTS,
Receiving \$185,000 Grant*

*"DM2006" was Organized by the
World Bank and **Bill Gates Foundation***

**Judges Were Scientists from
MIT- UCLA - Harvard**

STANDARD COAL POWER PLANT

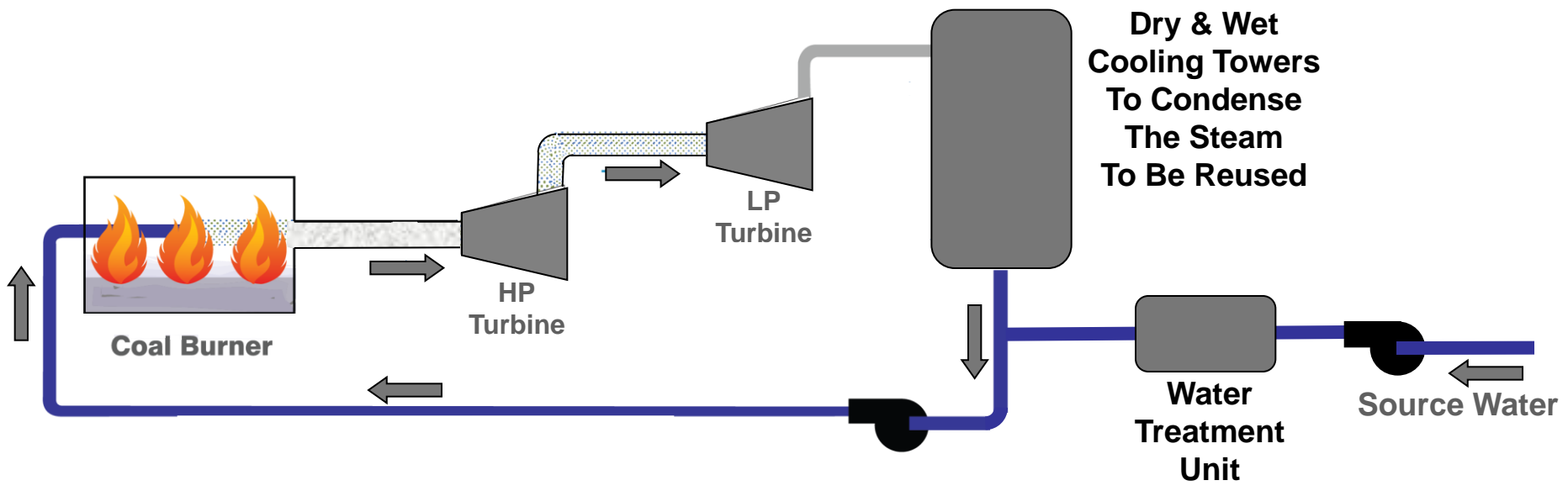

HITTITE Developed Different Models Of Applications For Industrial Plants

**HITTITE Desalination Technology
is Used to Condense the Steam Discharged
from Turbines,
While Simultaneously Treating Source Water
or Industrial Waste Water,
Replacing Costly Dry & Wet Cooling Towers.**

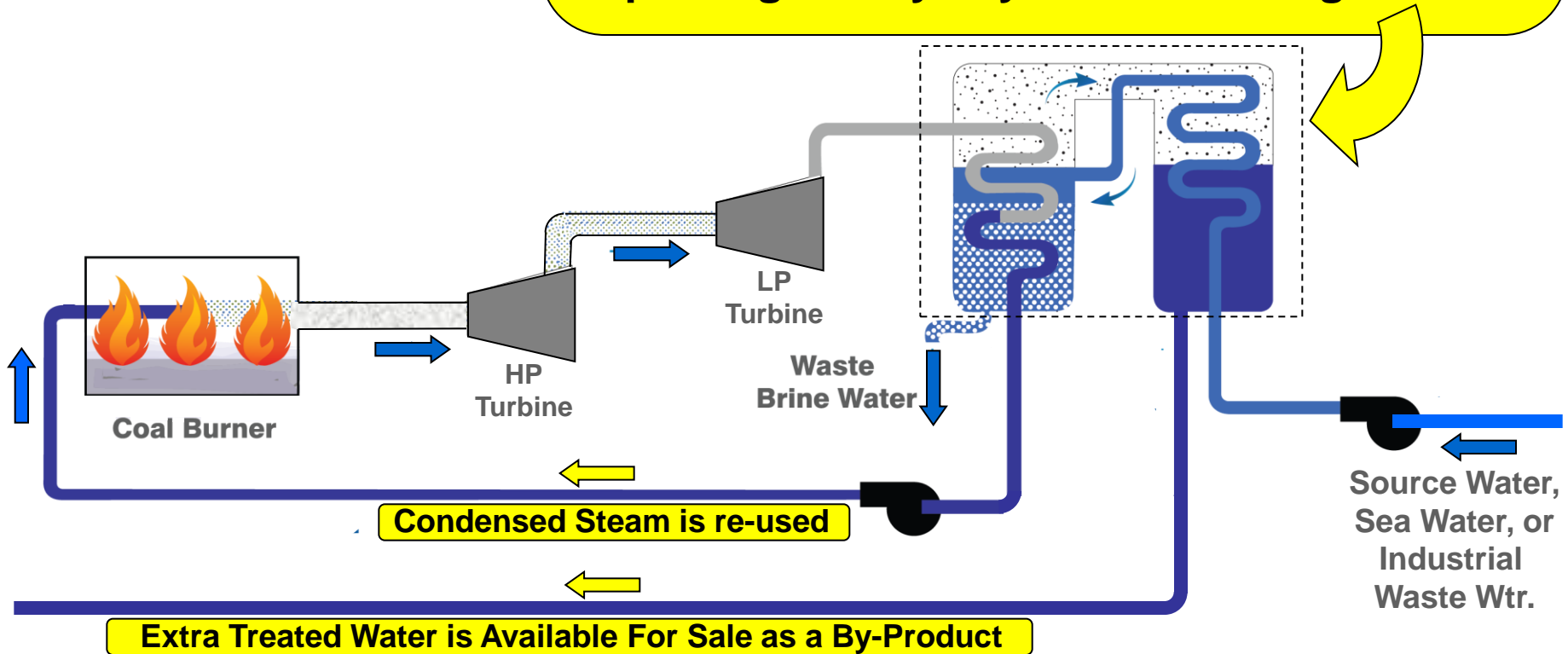

**HITTITE Developed
Different Models Of Applications
For Industrial Plants**

**HITTITE
Direct Steam Generating
Solar Field
Significantly Reduces
Coal Consumption**

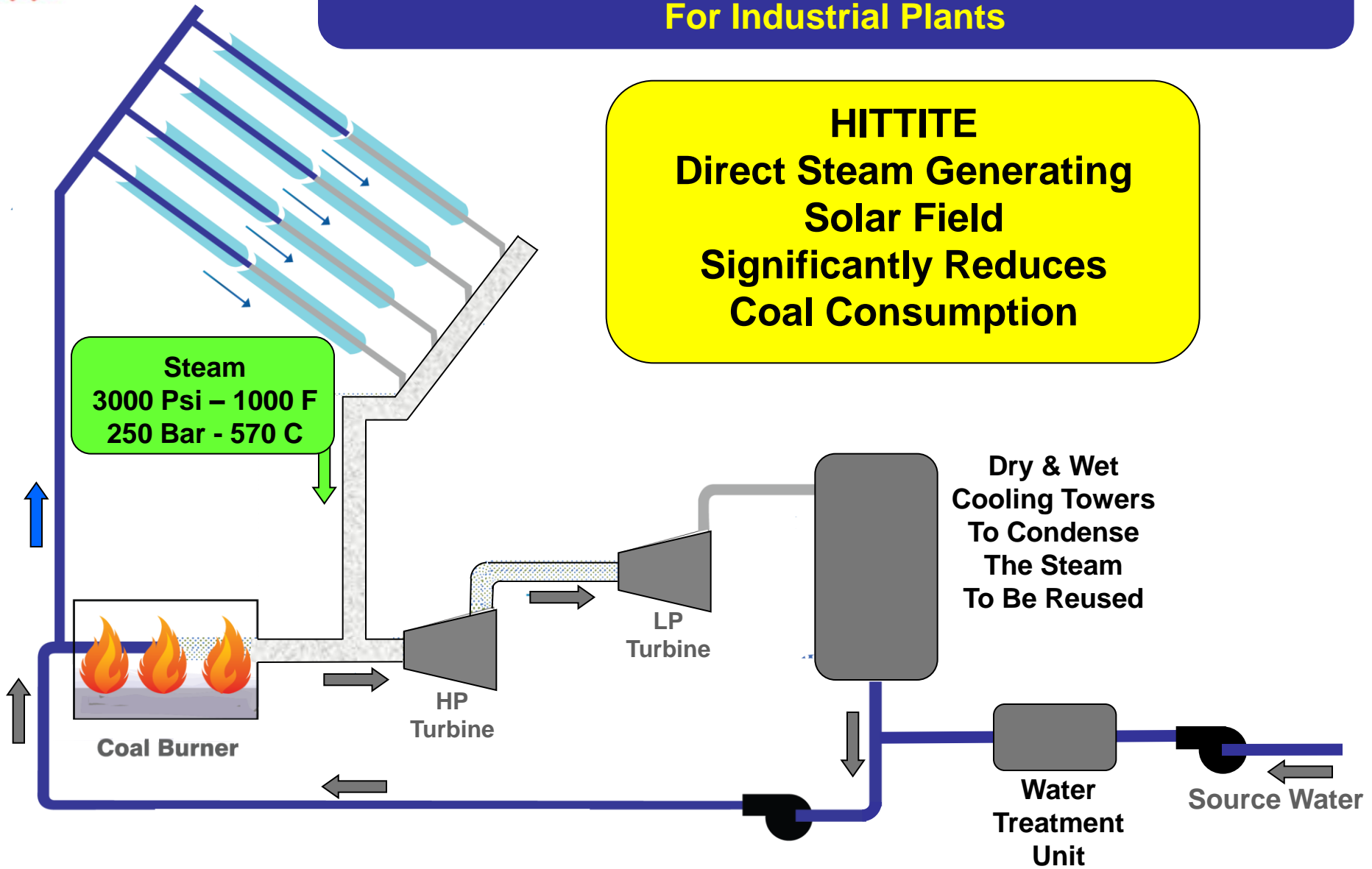

HITTITE Developed Different Models Of Applications For Industrial Plants

Combined Application Model Of Solar Steam & Water Treatment For Existing Coal Power Plants

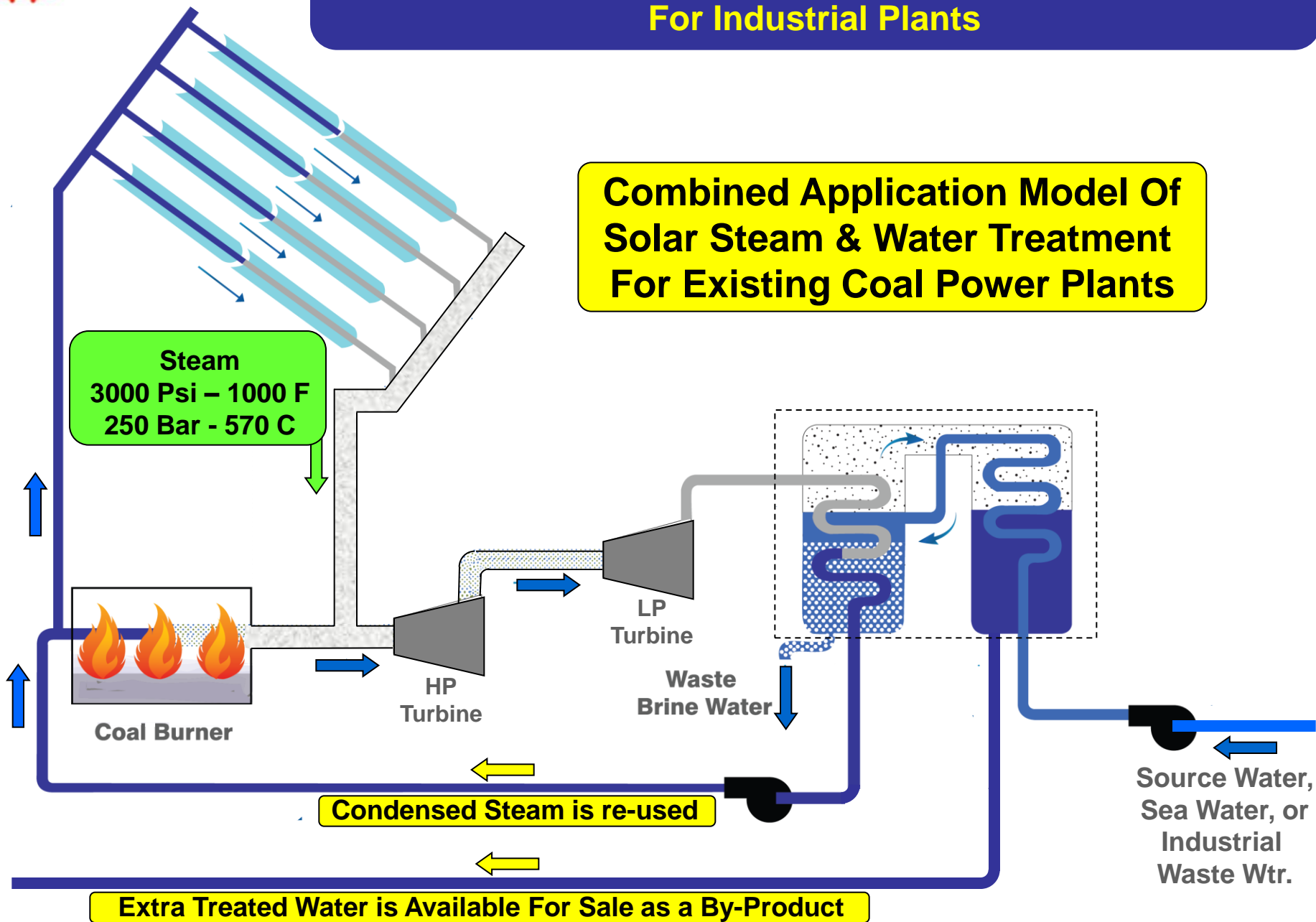

The Basic Concept Behind HITTITE Combined Application Model Of Water Treatment & Steam Condenser Technologies

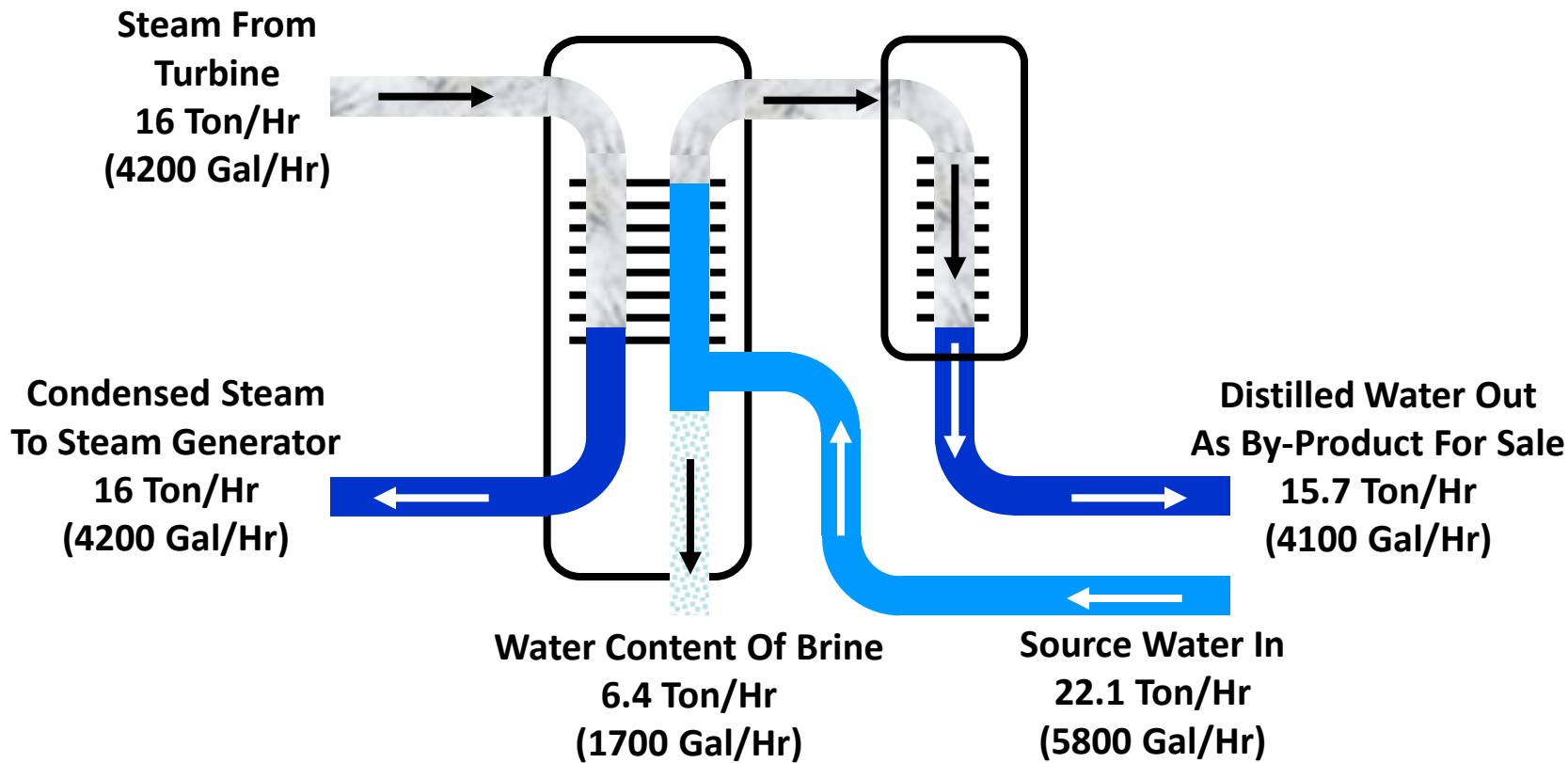

HITTITE Water Treatment System operates at low temperatures of about 45C (110F) which allows for condensation of steam discharged from turbines, while treating an almost equal volume of excess treated water. (Numbers shown here were developed for an existing coal power plant in SW USA.)

This model eliminates high energy consuming wet & dry cooling towers, RO, and generates excess treated water for sale as byproduct.

**Industrial Steam and Waste Water Treatment are
Larger and More Urgent Global Markets than
New Solar Thermal Power Plants
For Combined Applications of HITTITE Technologies**

- ☀ Provides Steam, Distilled Water, Waste Water Treatment to industrial Plants:
Paper Mills
Textile Plants
Food Processing Plants
Cement Plants
Desalinization Plants
Waste Water Treatment Plants
Heavy Oil Production
Augmenting poor quality Geothermal Plants
etc.***
- ☀ 95% of HITTITE Systems are designed to be fabricated locally in any country, creating employment.***